

VISTAS GENERALES

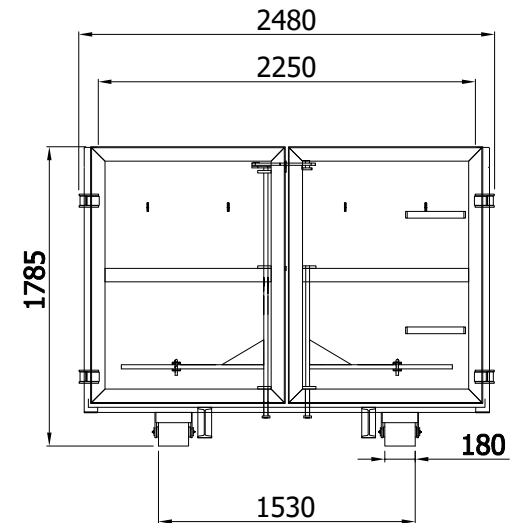
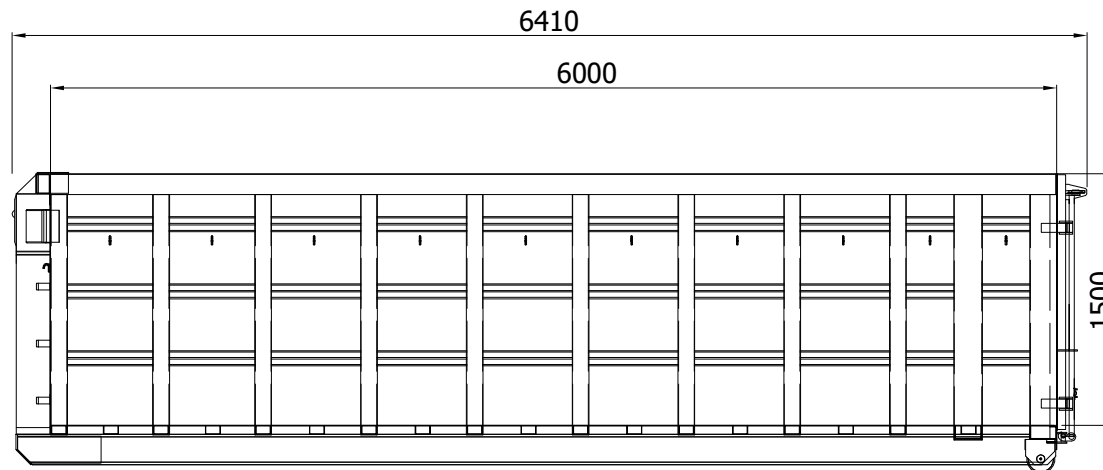
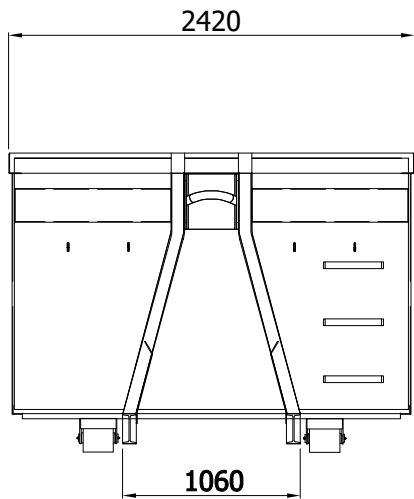

CARACTERÍSTICAS TÉCNICAS

DESCRIPCIÓN	CAJA FR REFORZADA		NERVAJE	CHAPA PLEGADA	
medidas en mm	6000x2250x1500		TRACCIÓN	CAYVOL-MULTILIFT-AMPLIROLL	
CUBICAJE	20 M3	CÓDIGO	110002	BASTIDOR	IPN-180 UCP-50 Ep.3mm
ESP. CHAPA	4/3 mm	PUERTA 2 HOJAS DE LIBRO	ACABADO	IMPRIMACION ANTIOXIDANTE	